

The Power Wave AC/DC 1000[®] was designed to be used for ALL SAW Applications

Designed to replace conventional transformer based DC only machines

Replace conventional DC equipment and still use existing WPSs for DC welding Machine has both DC+ and DC- modes for DC welding without changing cables

Designed to replace conventional transformer based AC only machines

Replace conventional AC equipment and still use existing WPSs for AC welding Machine has both 50 Hz and 60 Hz conventional sine wave AC modes

IMPROVE PRODUCTIVITY Through Flexible Waveform Control

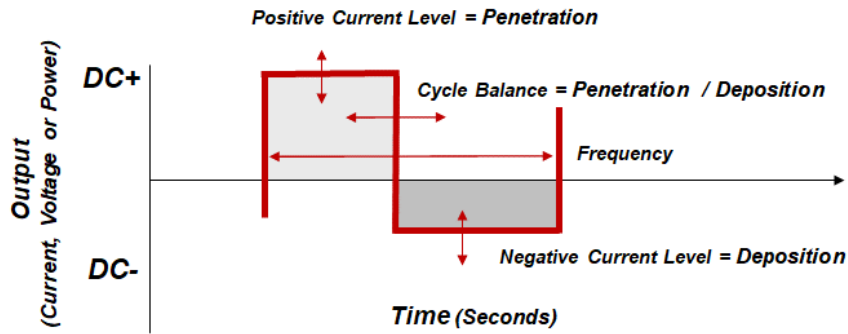

Move to the new generation of Submerged Arc Welding

INCREASE SPEED & PRODUCTIVITY by up to

200%

OPTIMUM SAVINGS & PERFORMANCE

MOVING YOUR SUBMERGED ARC SOLUTION TO THE NEXT LEVEL

Narrow Groove "Machined" Preparation

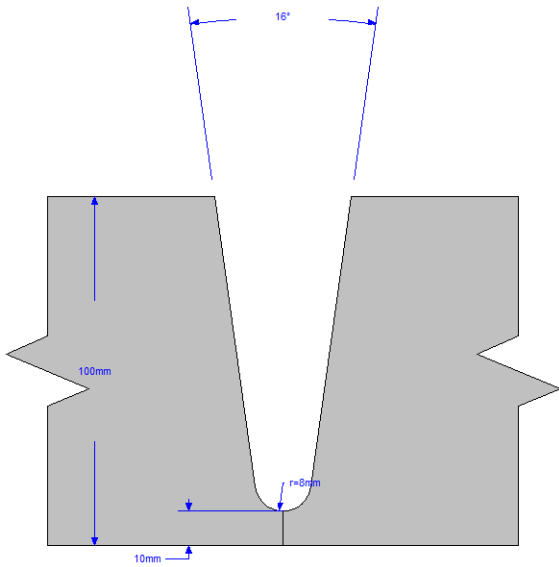

Narrow Groove Macrograph



Increased Deposition Rates = More Cost Savings

- » Increased Production Output
- » Faster Completion Times

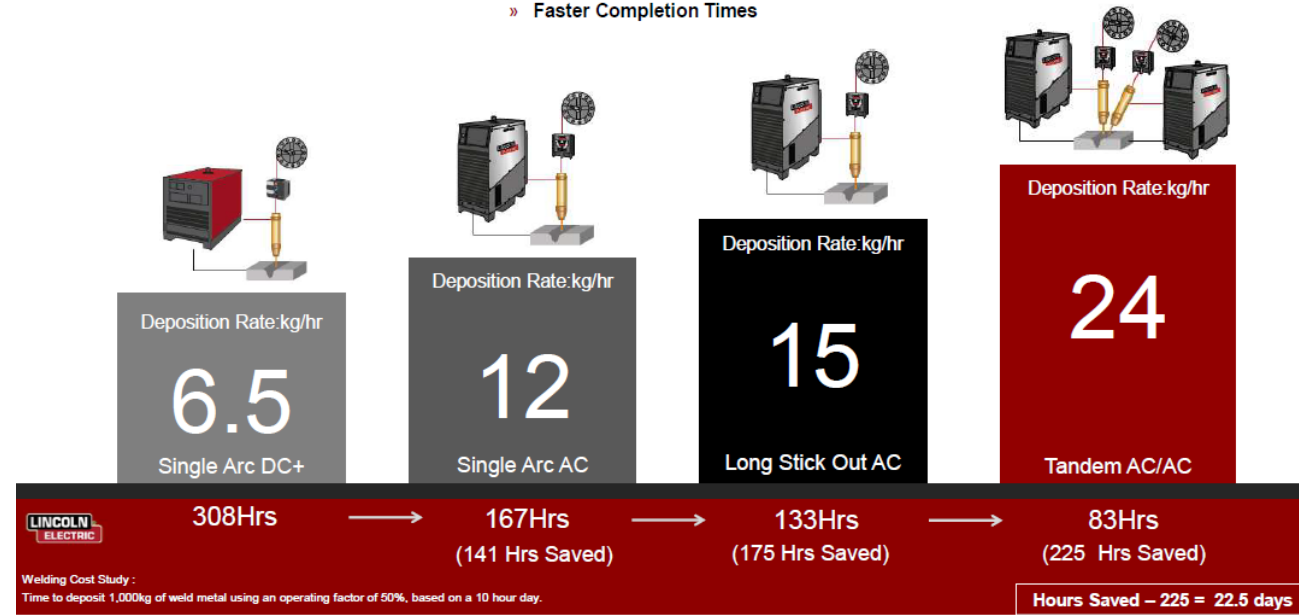

Double Bevel "Flame Cut" Preparation

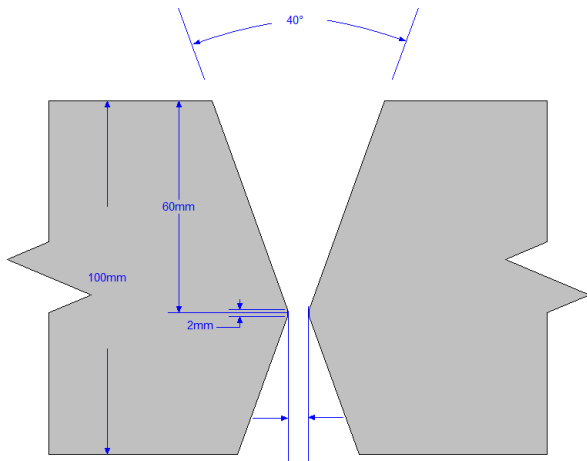

Double Bevel Macrograph

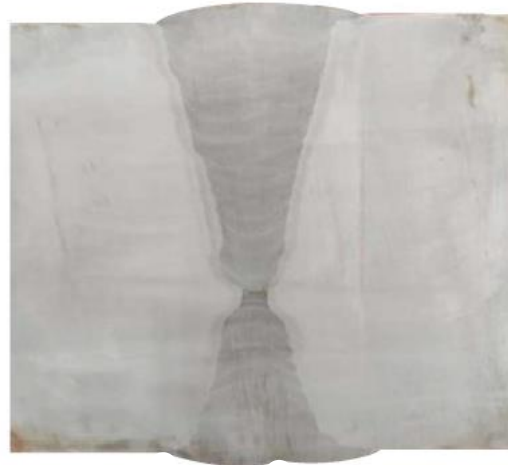

SOFTWARE DRIVEN CONTROL OVER PENETRATION, DEPOSITION RATE AND TRAVEL SPEED

